

TABLE OF CONTENTS

SECTION		PAGE
1	GENERAL DESCRIPTION.....	1
	Table I	2
2	CONTROL SPECIFICATIONS	3
	Table II	3
3	INSPECTION	3
4	INSTALLATION	3
	4.1 Mounting	3
	4.2 Wiring Procedure	5
5	INITIAL TURN-ON PROCEDURE	7
6	ADJUSTMENTS	7
	6.1 Adjustment Procedure Chart (Table IV)	9a
7	CONTROL OPERATION	10
8	TROUBLE SHOOTING	10
	8.1 Trouble Shooting Table... ..	10
	8.2 Trouble Shooting Procedure, 115V Controls	12
	8.3 Trouble shooting Procedure, 230V Controls	14
9	POWER CUBE TESTING	15
10	MOTOR TESTS	16
11	CONTACTOR OPERATED DRIVE	16
	11.1 Contactor Operation on the DC Lines	17
	11.2 Contactor Operation on the AC Lines	17
	11.3 Contactor Reversing	17
12	DYNAMIC BRAKING.....	18
13	EXTERNAL SIGNAL PROGRAMMING	18
	13.1 Speed Programming.....	18
	13.2 Torque Programming	19
14	TACHOMETER FEEDBACK	20
	Table VI.....	21
15	CHANGING CONTROL HORSEPOWER SIZE	21
16	MAINTENANCE – CONTROL	21
17	MAINTENACE – MOTOR	22
18	MAINTENANCE – SPEED REDUCER	22

1. GENERAL DESCRIPTION:

OC2 is an open chassis motor control that has been designed as a basic building block solid state regulated power unit. OC2, which uses state of the art control circuitry, can be used by itself, by wiring in the provided speed potentiometer as a straightforward speed regulated control, or can be incorporated into much more sophisticated system designs utilizing contactor operation, external speed programming, teach feedback etc. (These applications and others are discussed later in this manual.)

The control circuitry incorporates a sophisticated regulator scheme that maintains motor speed precisely at the set level within the advertised motor and control speed ranges. There are two control loops, speed and torque, that operate simultaneously and independently of each other. In most cases the speed loop is in control. (The speed loop can use either armature voltage or tachometer voltage feedback.) When in control, the speed loop maintains speed constant at the desired value until the motor load (torque) requirements exceed a preset value, normally 150% of rated motor torque. As this occurs, the torque regulator assumes control of the SCR's and allows speed to drop as is necessary in order to maintain and not exceed the preset limit value. If the motor load continues to increase, as would be the case if a driven machine had jammed, the torque limit is capable of holding this preset value of torque precisely without run out down to a locked rotor or zero speed condition. Operation in both the speed and torque modes is smooth and stable, and through the use of optimized networks transfer between the two loops is smooth and bumpless. Figure I is a block diagram of the OC2 control system.

In the speed mode the control holds the motor speed constant at a value determined by the voltage present at the Speed Input. In a basic control this voltage is set by a Speed potentiometer, but as will be explained later, could be set by other means of external speed programming. In most controls armature voltage is used as feedback in the speed (velocity) loop. When using armature voltage feedback, load changes are compensated for by an "IR" compensation circuit which senses any increase in armature current and raises the armature voltage to compensate for the increased voltage drop in the motor armature. This circuit thus controls the regulation (speed changes) due to load changes. The motor current is continuously monitored by a very low wattage dissipation current shunt. The signal from this shunt which is also used in the torque loop is then fed to the "IR" circuit which permits the achievement of no load to full load regulation of less than 1% of base speed. In application requiring load regulation better than 1% of base speed, tachometer feedback must be used.

The OC2 family covers horsepower sizes 1/8 through 3 HP as in Table I. It is possible to field convert the supplied control to some of the other horsepower sizes by changing the current shunt link. Table I indicates that the controls are divided into 3 sub-groups. Refer to the section in the manual entitled “Changing Control Horsepower Size” for specifics on how controls in a specific group can be field converted for use on different horsepower applications.

The OC2 unit is protected against excessive current overloads by the outstanding OC2 torque (current) limit circuitry. In addition, the OC2 unit is protected against damage due to accidental wiring shorts or grounds by fast-acting rectifier-protection type fuse(s) inserted in the AC input line(s). (In 115 volt controls, only one fuse is provided. Therefore, the non-fused AC line must be the ground line.)

WARNING

IF FUSE REPLACEMENT BECOMES NECESSARY, USE ONLY THE SPECIFIED FUSES. THE USE OF SUBSTITUTE FUSES MAY VOID CONTROL WARRANTY.

.....

TABLE- I

MODEL *	CONTROL VOLTAGE	CONTROL HP	NORMAL RMS INPUT CURRENT	RATED MOTOR CURRENT	SHUN LINK USED	FUSE TYPE **	CONTROL GROUP
OC2 -12	115V	1/8	2.5	1.45	A	B	1
OC2 -16		1/6	4.0	1.75	B	B	
OC2 -25		1/4	6.0	3.0	E	B	
OC2 -33		1/3	6.5	3.75	G	B	
OC2 -50		1/2	10.0	6.0	K	B	
OC2 -75		3/4	14.0	8.0	M	B	
OC2 -100		1	18.0	10.5	N	B	
OC2 -26	230V	1/4	3.0	1.45	A	C	2
OC2 -34		1/3	4.0	1.75	B	C	
OC2 -51		1/2	6.0	3.0	E	C	
OC2 -76		3/4	7.0	3.75	G	C	
OC2 -101		1	12.0	6.0	K	C	
OC2 -150		1 1/2	15.0	8.0	M	C	
OC2 -200	2	20.0	10.5	N	C		
OC2 -300	230V	3	30.0	15.0	P	D	3

Fuse Type B - (IR) SF13 X 25 OR (SHAWMUT) A13 X 25

Fuse Type C - (IR) SF25 X 25 OR (SHAWMUT) A25 X 25

Fuse Type D - (IR) SF25 X 30 OR (SHAWMUT) A25 X 30

* - On UL –recognized controls, the letter “U” will suffix the model No.

** - Only Shawmut fuses can be used on UL-recognized controls.

2 **CONTROL SPECIFICATIONS**

TABLE II

Input Voltage (single phase)	115VAC \pm 10 volts (115V Models) 230 VAC \pm 20 volts (230V Models)
Input Frequency	50 /60 Hz
Output Voltage to	0-90 VDC (115V Models)
Armature (Rectified and unfiltered).....	0 -180VDC (230V Models)
Output voltage to Field (Rectified and Unfiltered).....	100VDC (115V Models) 200VDC (230V Models)
Speed Range	0 – 100%
Load Regulation for 100% load change:	Adjustable to \pm 1% of base speed
a) With armature feedback	
b) With tachometer feedback	\pm .1% of base speed typical
Speed Range for Specified Regulation	20:1
Speed Dial Characteristics	Linear
Linear Acceleration Time	0.5 to 15 seconds adjustable
Torque Limit (% of Rated Motor Current)	Approx. 75 to 150% adjustable
Maximum Ambient Temperature	40° C
External Signal Capability	See section in manual

3. INSPECTION:

Check for shipping damage. If damage is found, report it to the carrier immediately. Do not attempt to operate the drive if visible damage to the circuit board or other component exists.

4. INSTALLATION:

4.1 MOUNTING

Four holes are provided in the base plate for mounting purposes. There is no preferred mounting position for the OC2 control. Four holes for mounting the OC2 should be drilled in the enclosure wall or sub-panel per the mounting dimensions shown either in A1402 -000-DD (Fig. 2. 115 volt controls) or A1404-000-DD (Fig 3. 230 volt controls). Apply an even thin coat of Dow Corning Compound #4 or equivalent to the bottom side of the base plate on the OC2 control to facilitate heat transfer.

When mounting in the enclosure, select an area that will minimize the possibility of metal parts falling between the PC board and OC2 base plate, or on the PC board and thereby causing shorts. Since the enclosure wall or sub-panel is actually used by the OC2 as a heat sink, it is necessary that the panel be of sufficient size to furnish adequate cooling. It is recommended that the 1 HP (115V only), and 2 and 3 HP controls be mounted on an enclosure at least 16" X 20", and that the internal cabinet temperature be kept below 55° C. If these conditions are met, no fans need to be used. Where it is necessary to go as high as a maximum 70° C internal cabinet temperature, a small fan should be added to move air across the base plate of the control where the semi conductors are mounted. A Rotron "muffin" fan (50 to 100cfm) or Pamotor Series 4500 is sufficient. No fan should be necessary on 1/8 through 3/4 HP (115V) and 1/4 through 1½ HP (230V) controls even when cabinet temperature reaches the maximum of 70° C limit if recommended enclosure size is used.

In some cases, it may be necessary to mount in a smaller enclosure than recommended. In these cases, it can be determined if a fan will or will not be necessary by measuring the power cube base plate temperature. The power cube base plate temperature under all conditions cannot exceed 90° C on all OC2 control sizes "-"except for the 3 HP control where the base plate temperature should not exceed 95° C.

4.2 **WIRING PROCEDURE:**

Use external drawing A1401-000-EW (Fig.4.) on 115 volt controls and A1404-000-EW (Fig,5) on 230 volt controls for proper external wiring connections. The rated RMS currents for specific horsepower sizes are given on these external wiring diagrams. Size all wires which carry armature current as given on the external connections drawing in the RMS line current column. (This is necessary to account for the form factor of the current being supplied to the armature of the motor.) All other wire connections may be #18 AWG.

On 115 volt controls the AC input connections are made on the base plate to 2TB. On 230 volt controls the input connections are made directly to the double fuse holder. These AC input wires should be lugged. Wire connections to terminal strip 1TB on the printed circuit board are not to be lugged. Strip 1/2" insulation from the ends of the wires to be connected to 1TB and insert wires under the wire clamps of the terminals. It is not recommended that wires smaller than #18 AWG be used to make connections to terminal 1TB since smaller wires may not be used adequately held by the wire clamping plate on the terminals. After wiring, make sure that there are no shorts to the chassis or shorts between terminals.

Caution should be observed when connecting the motor shunt field. Some DC motors are provided with dual field winding, which are connectable for high or low voltage.

The field voltage supplied on the OC2 control is as follows:

115VAC Input – 100VDC Field
230VAC Input – 200 VDC Field

A typical dual voltage field winding connection is shown below:

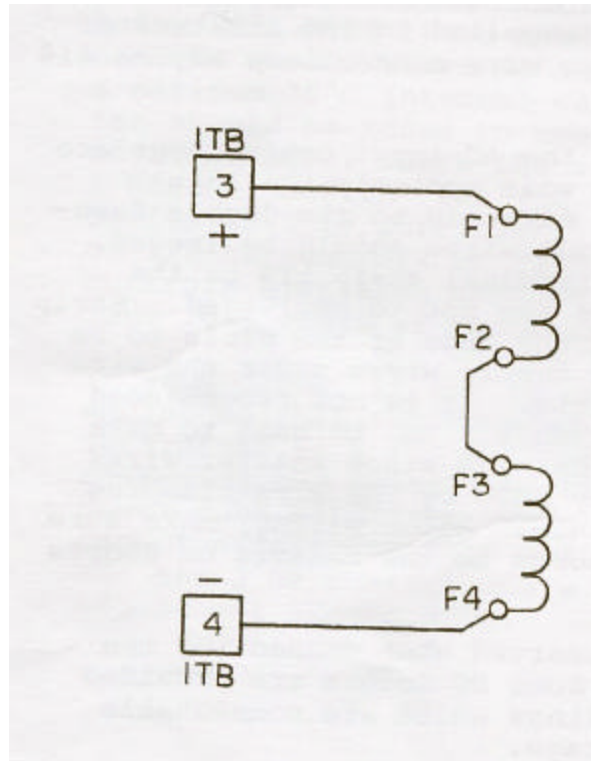

Refer to the wiring information plate found on the motor, and connect field windings for the proper voltage of the OC2. Some motors have permanent magnet fields. In this case no connections are made to terminals 3 and 4 on ITB.

5. INITIAL TURN –ON PROCEDURE:

Recheck all wiring. Accidental grounds on any of the motor leads or speed potentiometer wires may damage the unit when power is applied. Make sure that the AC service is of the correct voltage as indicated by the voltage warning label located on the control.

Before applying power, check to make sure the feedback select jumper on 2PL is in the “Arm” position, pins 1 and 2 on 2PL jumpered together, for controls using armature voltage feed-back. On controls that will use tachometer feedback, refer to the Tachometer Feedback Section 14 in this manual.

Turn the speed potentiometer to zero. Apply power from the AC disconnect switch. A LED located on the PC board will light indicating power is applied. (In contactor operated systems, also energize the DC contactor.) Slowly advance the speed potentiometer while observing the motor. If motor rotation is incorrect, turn power off at the AC disconnect and reverse the A1 and A2 connections to terminals on 1 & 2 on 1TB of the OC2 control. If the motor runs at maximum speed with the potentiometer fully counterclockwise, and slows down as the potentiometer is rotated clockwise, the potentiometer is wired in backward. With “Power Off”, reverse the outer leads of the speed potentiometer.

The control should be checked for satisfactory operation throughout the entire speed range. If instability is observed, maximum speed is higher than normal, or if acceleration time is not as desired, adjust the control as described in the following section. If initial operation is satisfactory, no readjustments are necessary.

6. ADJUSTMENTS:

Five internal adjustments are provided.

- a) Minimum speed (“MIN”)
- b) Maximum speed (“MAX”)
- c) IR (load)compensation (“IR”)
- d) Torque limit (“TORQ”)
- e) Acceleration (“ACC”)

The function of these adjustments is described in Table IV. All adjustments, except “IR”, are preset at the factory. A “typical” test motor is utilized. The “MAX” and “TORQUE” adjustments do not depend on individual motor characteristics and therefore should be correct as received. The “IR” and “MIN” adjustments, however, are somewhat dependent on characteristics of the particular motor used, and should therefore be made by the user when the drive is installed. Job-site adjustment of “IR” is necessary to achieve specified regulation. The adjustments are permanent; periodic readjustment is not necessary. (The IR adjustment is set fully counterclockwise when using tachometer feedback.)

Perform adjustments per Table IV and in the order listed in Table IV. The adjustments are completely independent of each other except as noted below:

- a) "IR" has a slight effect on "MIN", but "MIN" does not affect "IR"
- b) "MIN" has a slight effect on "MAX"

Thus performing adjustments in the order listed in Table IV eliminates any necessity for repeating a calibration operation.

Note that torque limit ("**TORQ**") is independent of the other adjustments. Since this is basically a protective adjustment, preset at the factory, it should not be readjusted except to decrease the limit point.

6.1 **ADJUSTMENT PROCEDURE CHART**

TABLE IV

ADJUSTMENT NAME	DESCRIPTION OF FUNCTION : NOTES	ADJUSTMENT OF PROCEDURE
<p>“IR”</p>	<p>Sets the load regulation (% slowdown of motor as shaft load is changed from zero to full rated load.)</p> <p>If load slowdown is of no concern, rotate “IR” trim pot fully counter clockwise.</p> <p>(In tach feedback systems, this pot must be turned fully counterclockwise.)</p>	<p><u>Approximate method:</u></p> <ul style="list-style-type: none"> a) Set speed control knob for 20% speed. b) Rotate “IR” trim pot clockwise until motor begins to hunt. c) Back off “IR” trim pot 1/3 rd of the span between this setting and zero setting. This method usually results in slight over-compensation. <p><u>Exact method:</u></p> <ul style="list-style-type: none"> a) Turn drive power off and connect a DC ammeter in series with the A1 motor lead between motor and control. Do not use clamp-on meter. b) Set speed control knob for 20% speed. c) Turn drive power on. With motor shaft loaded lightly, read motor speed with a strobe light or a tachometer. d) Load the motor shaft until ammeter reads rated motor current [see nameplate]. Red motor speed with strobe light or tachometer. e) If motor speed decreased as motor was loaded, adjust the “IR” trim pot and repeat (c) and (d) until little or no speed decrease is noted f) In performing (d) and (e), be sure motor is not loaded heavily enough to cause torque limiting to occur. g) Remove ammeter and reconnect A1 motor lead. Recheck control at very low speed for cogging
<p>“MIN”</p>	<p>Sets the zero calibration of the speed control knob.</p> <p>Clockwise rotation of “MIN” trim pot increases speed.</p>	<ul style="list-style-type: none"> a) Set speed control knob to zero b) Rotate the “MIN” trim pot clockwise until motor starts to rotate c) Decrease the “MIN” trim pot setting until rotation stops.

<p>“MAX”</p>	<p>Calibrates the speed at which motor turns when speed control knob is fully clockwise. Clockwise rotation of the “MAX” trim pot increases maximum motor speed.</p>	<ul style="list-style-type: none"> a) Turn drive power off. b) Connect a DC voltmeter between A1 and A2 motor leads at the motor. c) Set meter scale so that rated armature voltage (90 volts or 180 volts as noted on motor name- plate) may be read. d) Turn power on. Turn speed control knob fully clockwise. e) Adjust “MAX” trim pot until meter reads nameplate rated voltage (90 volts or 180 volts). <p>NOTE: If desired, a tachometer or strobe light may be used in lieu of the DC voltmeter. Proceed as described above, except adjust the “MAX” trim pot until tachometer or strobe light indicates that motor is turning at base speed.</p>
<p>“TORQ”</p>	<p>(Torque Limit) . Sets the maximum torque that can be obtained from the motor, and the maximum armature current that the control unit will deliver. Torque adjustment is preset at the factory usually for 150% of rated motor torque (current). Clockwise rotation of the “TORQ” trim pot increases the torque that the motor will deliver.</p>	<ul style="list-style-type: none"> a) Turn power off. b) Connect a DC ammeter (not a clamp-on type) in series with the A1 motor lead between motor and control unit. c) Turn power on. d) Set speed control knob for low speed (eg: 10% setting) e) Apply friction braking to the motor shaft until motor stalls out. CAUTION: Watch ammeter to assure that control is limiting current. f) Stall current should read roughly 150% of rated armature current (see motor nameplate) g) If current is too high, rotate the “TORQ” pot counterclockwise to decrease
<p>“ACC”</p>	<p>Acceleration adjustment sets time for motor to reach set speed</p>	<p>Adjust to desired acceleration time. Clockwise rotation increases time.</p>

7. CONTROL OPERATION:

Prior to shipment, all OC2 controls are tested and completely adjusted at the Polyspede factory. Therefore, after properly wiring and following the “Initial Turn-On Procedure” section, the control should be functioning properly. If the motor speed cannot be controlled, fuses blow, or other problems are experienced with the control, refer to the troubleshooting chart, the Trouble Shooting In Case Of Fuse Blowing section, and/or the Motor Test Section.

8. TROUBLESHOOTING

8.1 TROUBLESHOOTING TABLE

The majority of major malfunctions which are normally encountered can be summarized as stated below:

- a) Motor does not run.
- b) Motor runs only at full speed or over speed.
- c) System blow fuses or breakers repeatedly.

Table V tabulates these malfunctions, probable causes, and actions required for testing. If fuse blowing is the problem, read Table V and then follow the check out procedure of section 8.2 (115 Volt controls) or Section 8.3 (230 Volt controls)

WARNING

**DANGEROUS VOLTAGES ARE PRESENT ON THE
CONTROL CIRCUIT BOARD AND TERMINALS.
ONLY PERSONNEL FAMILIAR WITH ELECTRICAL
TEST PROCEDURES, TEST EQUIPMENT, AND
SAFETY PRECAUTIONS SHOULD ATTEMPT
THESE TESTS**

TABLE V
TROUBLE SHOOTING

MALFUNCTION	POSSIBLE CAUSE	ACTION
<p>a) Motor does not run or will not run to top speed.</p>	<p>a) AC input to control missing. (“PWR ON” LED also will not light)</p> <p>b) Fuse blown (PWR ON LED also will not light)</p> <p>c) Motor jammed mechanically.</p> <p>d) Field voltage low or missing, causing insufficient torque under heavy loads. (Does not apply to PM motors)</p> <p>e) Motor field open or disconnected and operating under heavy load. (Does not apply to PM motors)</p> <p>f) Terminals RST1 and RST2 on TB2 not connected.</p>	<p>Check AC line voltage</p> <p>Remove, check, and if necessary replace fuse (s)</p> <p>Check by rotating the shaft manually.</p> <p>Check field voltage between terminals 3 and 4 on 1TB. Should read: a) 100VDC on 115V input control. b) 200VDC on 230V input control</p> <p>Check motor field wiring. Check resistance as given motor tests with the power off. Either a permanent jumper or contact closure must be used to permit control operation. See the external wiring diagrams and contactor operated systems section.</p>

<p>b) Motor runs only at full speed. (In tach feedback system, proper maximum voltage cannot be adjusted.)</p>	<p>a) Motor field open or disconnected and operating under light load. (Does not apply to PM motors.)</p> <p>b) Motor field voltage low or missing and operating under light load. (Does not apply to PM motors.)</p> <p>c) Tach feedback: Control board improperly set up for tach and motor combination, or mini jumper is missing between pins 2 and 3 on FB SELECT plug 2PL. (For armature voltage feedback, pins 1 and 2 are jumpered together)</p> <p>d) External speed potentiometer not properly connected.</p> <p>e) Problems in the control board circuitry.</p>	<p>Check motor field wiring. Check resistance of the field as given in motor tests with the power off.</p> <p>Check field voltage. Field voltage should be :</p> <p>a)100VDC on 115V input control. b)200VDC on 230V input control</p> <p>Refer to the tach feedback section for proper board set-up.</p> <p>Speed potentiometer resistance should measure 1K. With potentiometer wired voltage between terminal 6(+) and (5) should vary 0 to 6VDC. Return to the factory for repair.</p>
<p>c) Repeated Control fuses blowing.</p>	<p>a) Incorrect AC input voltage.</p> <p>b) Incorrect Connections between motor and control.</p> <p>c) Shorts between internal control wiring and mounting base.</p> <p>d) Shorts in external wiring</p> <p>e) Faulty SCR Power diodes and/or field diodes.</p>	<p>Check that voltage supplied agrees with voltage warning label.</p> <p>Recheck all motor connections as given on: A1401-000-EW (115V Controls) A1404-000-EW (230V Controls)</p> <p>Visual inspection and routine checks.</p> <p>Refer to section on testing in case of fuse blowing.</p> <p>Refer to section on testing in case of fuse blowing.</p>

8.2 **TROUBLESHOOTING PROCEDURE - IN CASE OF FUSE BLOWING,
ALL 115 VOLT CONTROLS**

If fuses blow, a light bulb checkout procedure may be used without danger of damaging the control and without excessive fuse blowing during checkout. Proceed as follows:

- a) Turn power off at the source disconnect ahead of the control.
- b) Connect a 120 volt, 100 watt bulbs in series with the underground AC input line (L1)
- c) Replace any blown control fuse(s) with a good fuse (s)
- d) Disconnect A1, A2, and field wires at the motor. Insulate wire ends.
- e) Turn power ON at the service disconnect.

On controls without a DC loop contactors, make sure terminals 10 and 11 on 1TB are shorted together. On controls with a DC loop contactor make sure that an auxiliary contact working in conjunction with the contactor is closed when the DC contactor is energized. The bulb should not burn at any setting of the speed control pot. If the bulb does not light, move on to step (g). If the bulb does light, turn off power and remove all connections to terminal 1TB. Reapply 115 volts to the control. If bulb does not glow, trouble is probably a short in the external wiring. Rewire the external wiring, one wire at a time until the wire (s) causing the problem are located. Replace any defective wires. If the bulb still burns after all external connections have been removed, move on to step (f). If the problem has been corrected, move on to step (g)

- f) This step is to be done if step (e) shows that the light bulb still lights with all external connections removed including A1, A2, F1, and F2. This probably indicates that the OC2 SCR's, field diodes, and/or power diodes are defective.

Only the power cube containing the complete power bridge is considered field replaceable. The power cube should be checked per Section 9. Replace the power cube, if found to be defective. After replacement, the control should again be rechecked with all external connections removed. If the light bulb still lights, the field diodes, D1 and D2 on the E1507 PC board, are probably the cause of the problem. Since these components are not recommended as field replaceable, the E1507 PC board should be replaced or the entire control should be returned to the Polyspede factory for repair. If the bulb does not light, turn power off and reconnect the speed pot connections and any other external connections to 1TB if they are presently not connected. (A1, A2 and motor field leads are still disconnected at motor.) Reapply power. If, with the speed pot at zero, the bulb burns, go back to step (e). If the bulb does not burn, go to step (g).

- g) If no faults are located in the preceding steps, or if they have already been corrected, leave light bulb connected as in the preceding steps and reconnect A1 and A2 wires at the motor. Leave field wires disconnected and insulated. All wires at this point should be connected except the field wires. Set the speed control pot at zero and turn on all power. Light should not burn. Increase the speed setting to 20%. Lamp brilliance should increase smoothly to nearly full brilliance. (NOTE: Lamp flicker and erratic brilliance may be observed at settings above 15 – 20%; this is normal.) The FB SELECT plug 2PL should have pins 1 and 2 jumpered together during this step.
- h) Repeat step (g) with motor field wires connected. Results should be similar except that the bulb will burn at about ½ brilliance with speed control set to zero due to motor field current, and will increase to nearly full brilliance at a 15% or 20% setting of the speed pot. (If the control is used on a PM motor, skip this step.)
- i) If operation is normal in all preceding steps, remove light bulb and reconnect all wiring for normal operation.

- j) If occasional fuse blowing occurs, an intermittent short or ground is indicated. Inspect motor leads and motor brush pigtails for possible faults. Inspect the OC2 control unit for loose foreign objects (washers, nuts, wire clippings, etc.). Test all internal wiring. If the problem seems to be in the DC motor, refer to the Motor Tests - Section 10.

8.3 **TROUBLE SHOOTING PROCEDURE – IN CASE OF FUSE BLOWING, 230 VOLT CONTROLS**

If fuses blow, a light bulb checkout procedure may be used without the danger of damaging the control and without excessive fuse blowing during checkout. Proceed as follow:

Perform all of the steps used in the checkout of 115 volt controls previously explained except with the following changes:

- a) Use two 115 volt 100 watt bulbs connected in series in each of the two AC input lines (a total of four bulbs). This is necessary since both lines may be “HOT” in a 230 volt service and either line may be susceptible to faults to ground.
- b) Results should be the same in the preceding section for 115 volt controls except that bulb brilliance may be less than that described for 115 volt controls because of the number of bulbs used.

9. **POWER CUBE TESTING (115 AND 230 VOLT CONTROLS):**

The power cube houses two SCRs and three diodes in a configuration shown in Fig. 6. Simple tests with an ohmmeter cannot conclusively show that an SCR or a rectifier is good, but shorted or open SCRs or rectifiers can be detected. Remove all wires connected to the power cube. Refer to Fig. 6. Using a Simpson 260 meter or equivalent, make the following measurements:

- a) With the meter between the “AC 1” and “+” terminals on the power cube, the meter should read high (several hundred K ohms) when “AC1” is either plus or minus in respect to the “+” terminal. The other SCR can be checked in the same manner by putting the meter probes on the “AC2” and “+” terminals.

- b) The diodes can be checked by putting one lead on the “-”, terminal. The other lead should be put on the “+”, “AC1” or “AC2” terminal to check each of the three diodes. . With the meter leads on the “+” and “-” terminals and the Simpson on the RX1 resistance scale, the meter should read between 515 ohms when the “-” terminal is positive in respect to the “+” terminal. With the meter voltage polarity reversed, the meter will read high. Going to a higher meter resistance scale such as RX 100 or RX 10,000 will indicate resistance greater than 100K ohms. In the same manner the diodes can be checked by placing one meter lead on the “-” terminal and the other lead on either the “AC1” or “AC2” terminals. Replace the bridge if found to be faulty. Reconnect the bridge as shown in drawing A1402-000-ES, Fig. 7 (1/8 through 1 HP, 115V); A1404-000-ES, Fig. 8(1/4 through 2 HP, 230V); or A1405-000-ES, Fig. 9 (3 HP, 230V).

10. **MOTOR TESTS**

The following tests will be helpful in pinpointing possible motor problems. Before making any tests, **remove** the armature and field leads from the control.

- a) Shorts to the Frame - Using a Megger set for 400 volt test potential, check leakage resistance between the A1, A2, motor field leads and the motor frame. Readings of less than 10,000 ohms indicate possible problems. A dead short indicates need for immediate repair. Checks for dead shorts may be made with an ohmmeter or a continuity tester if a Megger is not available. Retest while rotating armature by hand.
- b) Open or Shorted Field - A resistance check between F1 and F2 (also F3 and F4) should indicate a resistance between 100 to 600 ohms.
- c) Open Armature - An ohmmeter between A1 and A2 should indicate a resistance of less than 10 ohms. Rotate the motor shaft very slowly, while observing the ohmmeter. Because of the residual magnetism on shunt field motors or the field on permanent magnet motors, a CEMF will be produced in rotating. This will cause the ohmmeter readings to change during rotation. Therefore, after moving the shaft a small amount, stop and check the resistance reading. A high resistance reading at any position of the rotated motor shaft when it is stopped is a trouble indication. Armature opens are usually the result of bad brushes, burned commutator segments, or severed wires.

11. **CONTACTOR OPERATED DRIVE:**

In certain applications it may be necessary to start and stop the OC2 motor control through use of a magnetic contactor. The contactor may be used to make and break the two AC lines, or it may break the two armature lines A1 and A2.

11.1 **CONTACTOR OPERATION ON THE DC LINES**

If the contactor is connected to make and break the DC lines (A1 and A2), a third set of normally open contactor contacts must be provided and connected to 1TB terminals 10 and 11. This contact, which closes to run, replaces the factory installed wire jumper that is normally supplied with the control. This contact should be a signal level contact. A gold contact is desirable but not mandatory. Opening of the contact between terminals 10 and 11 instantaneously resets the controlled acceleration circuitry and prepares it for restarting when the contactor is again activated. Failure to remove the permanent wire jumper when using this contact could cause fuse blowing and/or severe drive damage.

11.2 **CONTACTOR OPERATION ON THE AC LINES**

If the contactor is connected to make and break the AC input lines, the reset auxiliary contact is not necessary. In this situation the factory installed wire jumper must stay connected. It is also necessary to allow two seconds to elapse between contactor activations to allow the controlled acceleration circuit to “bleed down” and reset. (Rapid jogging is not permitted) Failure to allow sufficient time to reset may cause fuses to blow on the next start-up cycle.

11.3 **CONTACTOR REVERSING**

External contactors or manually operated switches maybe used to reverse motor rotation. This is accomplished by physically reversing the external connections between 1TB terminals 1 and 2, and the A1 and A2 armature lines to the motor. In designing a reversing setup the following conditions must be met:

- a) The contactors (or switches) must be electrically or mechanically interlocked such that forward and reverse contactors cannot be activated simultaneously. Simultaneous operation would short out the control output and cause fuses to blow.

- b) Auxiliary contacts must be provided on both the forward and reverse contactors such that 1TB terminals 10 and 11 are activated, but opened when neither contactor is activated (controlled acceleration reset).
- c) The motor must be allowed to stop rotation before it is reversed. Reversing electrical power to a rotating motor (“plugging” the motor) causes high inrush currents which may damage the control unit, causes fuse blowing, or cause motor commutator damage. In custom-designed OC2 systems, Polyspede provides an anti-plugging relay which senses CEMF due to motor rotation and electrically inhibits activation of any contactor until motor rotation ceases.

12. **DYNAMIC BRAKING**

. In a contactor – reversed or high inertial system, it may be desirable to provide braking to cause rapid stopping of the motor and permit quicker reversing. If a power resistor is connected across the motor armature leads, A1 and A2, after the motor has been disconnected from the OC2 unit by contactor release, the motor will act as a generator and brake to a stop. The braking resistor must be removed from the circuit before reconnecting the motor to the OC2 output. In some cases such as high inertial loads, dynamic braking is also used on non-reversing drives to achieve faster stopping times.

13. **EXTERNAL SIGNAL PROGRAMMING:**

13.1 **SPEED PROGRAMMING**

Instead of using the standard speed potentiometer, the OC2 control unit can be programmed by a master reference unit, a current signal from a process instrument controller, an external signal from a DC tachometer or other DC voltage sources. Basically, any DC voltage which is isolated from the AC power lines and which varies from zero to six volts, may be applied between 1TB terminals 6(+) and (5) on 1TB to vary the speed from zero to 100%. Speed will vary directly and linearly with the applied voltage. Also, the control will not significantly “load” the signal source since its input impedance at terminal 6 is high (approximately 100 K) in respect to common. The following general procedure applies to permit external speed programming:

- a) Disconnect the 3 speed pot wires from 1TB terminals 5, 6, and 7.
- b) Connect the external signal source to terminals 5 and 6 as shown in Fig. 10.1
- c) If the external signal source is not isolated from the AC lines or if this signal is to be used by more than one drive, the AC power must be supplied to the OC2 control via an isolation transformer or a signal isolator PC board must be used. When a process instrument controller is used having an output which normally is 1-5, 4-20, or 10-50 ma, a signal isolator board should be used in order to convert to a 0 to 6 volt level and to set the drive minimum speed properly. See Fig. 10.2

13.2 TORQUE PROGRAMMING

An external signal may be used to program torque. A voltage of 6 volts will give that torque preset by the internal torque pot when using the 6 volt board power supply. If a larger value of programming voltage is available, it must be scaled down by a voltage divider network so that the maximum voltage that appears at 1TB -8(+) in respect to 1TB-5 (com) is 6 volts. A voltage variation of from zero to 6 volts between terminals 8 (+) and 5 (com) on 1TB will program a maximum torque capability of from zero to that value preset by the internal torque control potentiometer. Normally the internal torque potentiometer is set to limit current at 150% of rated current when internal torque programming is used. When external torque programming is used, the "torque" potentiometer on the E1507 PC board is in many cases readjusted so that with 6 volts present at 1TB-8 in respect to common the control will limit current to 100% of rated current. (The "torque" potentiometer on the E1507 PC board has sufficient range to limit current anywhere from approximately 75% to 150% of rated motor current with 6 volts present at terminal 8(+) in respect to common. When the control is supplying 100% of rated motor current, there will be, approximately, a 33 mv voltage drop across the current shunt 1MSH.on the E1507 PC board. In order to accomplish external torque programming, the yellow jumper on the E1507 PC board must be unsoldered from the "Int. Torq." position terminal, then resoldered to the "Ext.Torq" position terminal.

TACHOMETER FEEDBACK

The OC2 can easily be transferred to tachometer feedback by means of changing the position of the FB select jumper on 2PL. With pins 1 and 2 jumpered together, the OC2 uses armature voltage feedback. With pins 2 and 3 jumpered together, the control uses tachometer voltage feedback. Initially, the drive should be operated in the armature voltage feedback mode. A measurement can be made to determine proper tachometer polarity and approximate magnitude. The procedure to use is as follows:

- a) Refer to Table V for necessary board modification if any. The control has been set up to handle the most commonly used base speed motor and tachometer combinations. Table VI gives the base speed and tachometer voltage ratings that will work with the board as designed. For some combinations, a resistor must be clipped from the board. For motor and tachometer combinations not covered in this manual, consult the Polyspede factory for the necessary modification.
- b) Connect the tachometer leads so that the positive lead connects to terminal 9 (“TACH”) and the negative side to terminal 5 (“COM”). If the drive system is connected for reversing, the tachometer leads must be reversed when motor rotation is reversed so that terminal 9 is always positive in respect to common. Polarity can be easily checked by running the control connected for armature voltage feedback and checking the tachometer for voltage polarity as specified.
- c) With the control off, the jumper connecting pins 1 and 2 on the FB select plug should be changed to connect pins 2 and 3. (The jumper can be removed by vertically sliding the jumper off the plug pins.)
- d) Set the IR pot to the zero, fully counterclockwise position. Failure to do so can cause drive instability when using tachometer feedback.
- e) When running using tachometer feedback, it will probably be necessary to readjust the “MAX SPEED” adjustment. Rotate the max speed fully counterclockwise. Set the speed potentiometer for maximum speed. Adjust the “MAX” potentiometer clockwise until motor reaches desired maximum speed or until voltmeter reads 90 volts (115 volt input controls) or 180 volts (230 volt controls), whichever occurs first.

TABLE VI

BASE SPEED OF MOTOR RPM	TACHOMETER VOLTAGE	RESISTOR TO BE CLIPPED FROM BD
1150	50VDC /1000 RPM	NONE
1750	50VDC /1000 RPM	R22
2400	50VDC /1000 RPM	R18
1150	100VDC /1000 RPM	R18
1750	100VDC /1000 RPM	R18

15. CHANGING CONTROL HORSEPOWER SIZE:

Although there are at least 15 distinct models, the OC2 control is in actuality broken down into three major groups. Within each group and between some groups, control horsepower sizes can be changed by substituting an appropriate shunt link. . The following is a listing of the three groups in which horsepower sizes can be varied:

GROUPING

1. OC2-12 through OC2-100 115V (1/8 through 1 HP) control can be used on 1/8 through 1 HP, 115V applications. (Power cube version only.)
2. OC2-26 through OC2-200 230V (1/4 through 2HP) control can be used on 1/4 through 2 HP, 230V applications.
3. OC2-300 3 HP 230V. Control could be downgraded for use on 1/4 through 2 HP, 230 V application use if needed.

When changing shunt links, it is mandatory that the new shunt be mounted in the same sequence to the board standoffs. The shunt link should be positioned first on the standoffs and the other hardware mounted next. Select shunt link from Table I, page 2.

16. MAINTENANCE – CONTROL:

The control requires practically no maintenance once it has been installed. It is a rugged piece of equipment, but can be damaged if abused.

IF FUSE REPLACEMENT BECOMES NECESSARY, USE ONLY THE SPECIFIED FUSES. THE USE OF SUBSTITUTE FUSES MAY CAUSE CONTROL DAMAGE AND VOID THE CONTROL WARRANTY.

Correct fuses to be used are listed in Table I on page 2 of this manual.

17. **MAINTENANCE - MOTOR:**

Polyspede motors are rugged machines specifically designed for SCR controllers. There are no adjustments to make and maintenance is quite simple. All moving parts are subject to wear. Brushes are perhaps the only component requiring periodic maintenance.

Motor brush life is related to motor speed, loading, cycling rate, ambient temperature and other variables not controlled by Polyspede. Therefore, only guide lines can be given for checking this item. Experience has shown that each application has its own wear rate. Removal of the brushes after each three months of operation during the first year will give an indication of your specific wear rate. After three sets of brushes have been used, remove the motor armature for checking by a competent motor repair shop for possible commutator refacing.

Armature bearings are sealed and require no additional lubricating. Replacement should be performed by a reputable service shop if they become noisy.

Occasional cleaning of motor vent holes or removal of fan guard to remove dust accumulation from fans is the only additional maintenance required.

18. **MAINTENANCE – SPEED REDUCER:**

1. Use type and grade oil specified on the gear reducer nameplate. Keep in mind proper viscosities for various temperatures.
2. Keep oil at proper level.
3. Drain, flush, and refill reduction unit after initial run-in period.
4. Replace shaft seals at first sign of leakage not only to avoid damage due to loss of lubricant, but also to eliminate the possible entrance of contaminants into housing.
5. If detailed instructions for assembly and disassembly of a particular unit is required, write to the speed reducer factory for the information.
6. If your drive is coupling connected, and requires lubricating, the coupling should be checked on start-up and semi-annually.

OC2 BLOCK DIAGRAM

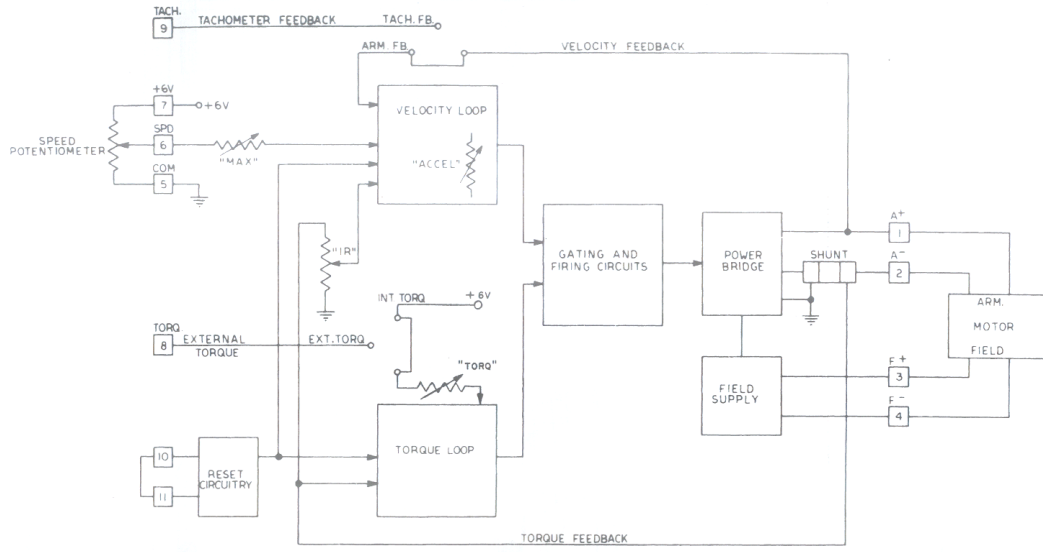

FIGURE 1

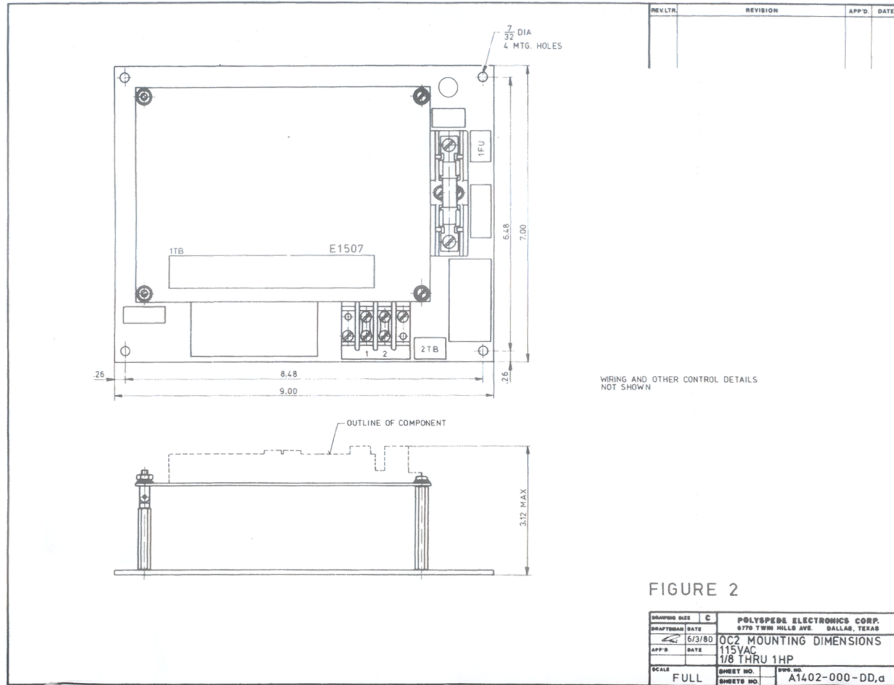
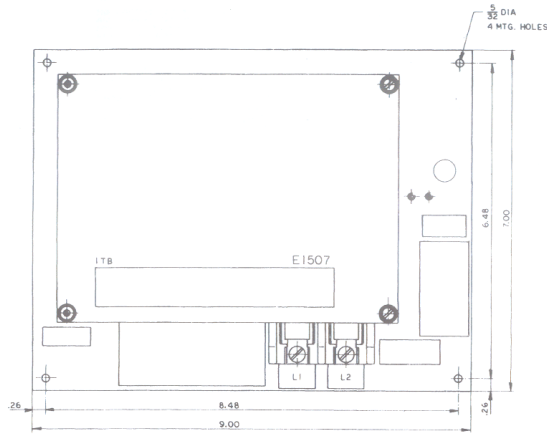

FIGURE 2

Drawing size	C	POLYSPER ELECTRONICS CORP.
Manufacture date	6/3/80	8701 TERRY HILL RD. DALLAS, TEXAS
APP'D	DATE	OC2 MOUNTING DIMENSIONS
	1/18/80	1TB THRU 1HP
SCALE	FULL	DWG. NO.
		SHEET NO.
		A9402-000-DD,d

REV/LTR.	REVISION	APP'D.	DATE



WIRING AND OTHER CONTROL DETAILS NOT SHOWN.

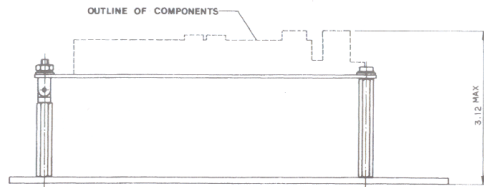
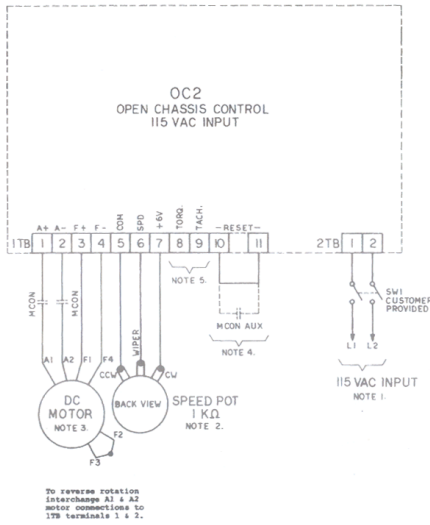

FIGURE 3

DRAWING SIZE	C	POLYSEPE ELECTRONICS CORP.
DRAFTSMAN	DATE	8770 TWIN HILLS AVE. DALLAS, TEXAS
APP'D.	DATE	8/9/76
SCALE	SHEET NO.	DWG. NO.
FULL	1	A404-000-DD,0

REV/LTR	REVISION	APP'D	DATE
a	NOTE 4 MODIFICATION		D.A.R. 9/8/76
b	REVISED NOTE 6		L.M. 7/20/78



- NOTES:**
- Only the AC line connected to 2TB-1 is fused. Therefore, L2 must be the grounded 115V AC Line.
 - The speed potentiometer, knob, and dial are provided with the control. The leads from this potentiometer should be kept as short as possible and run in a separate conduit from the AC input and motor leads.
 - If motor does not have F3 and F4 leads, connect F2 of the motor to 1TB-4 (F) on the control. Check that motor voltages are compatible with OC2 outputs:
 - Terminals 1 to 2 on 1TB 0-90VDC
 - Terminals 3 to 4 on 1TB - 100VDC
 (on permanent magnet motors no connections should be made to terminals 3 and 4)
 - The dashed contacts in series with the A1 and A2 leads of the motor are shown if a DC loop contactor is to be used. With a DC loop contactor remove the fixed jumper between terminals 10 and 11 on 1TB. In its place use an auxiliary N.O. contact on the DC loop contactor. The OC2 control is reset when the contact is open and able to run when this contact is closed. Failure to remove the fixed jumper and to use the M COW auxiliary contact will cause fuse blowing and possible control damage.
 - For applications requiring external torque programming and/or tach feedback, refer to manual P100-38 for necessary connections and board modifications.

FIGURE 4.

DESIGNER	C	POLYPHASE ELECTRONICS CORP.
DATE	8/2/76	8775 FIVE BILLS AVE. DALLAS, TEXAS
APP'D		OC2 EXTERNAL WIRING CONNECTIONS 115 VAC 1/8 THRU 1 HP
SCALE		
REVISION NO.	1	REVISED
QUANTITY NO.	1	A1401 7-EW,b

REV.	REVISION	APP'D.	DATE
B	NOTE 4 MODIFICATION		D.A.R. 9/8/76
D	REVISED NOTE 6.		L.M. 7/20/78

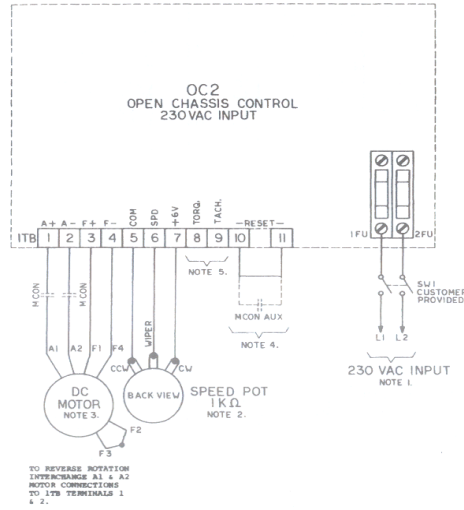

NOTES:

1. BOTH SIDES OF THE 230 VAC INPUT LINES ARE FUSED.
2. THE SPEED POTENTIOMETER, KNOB, AND DIAL ARE PROVIDED WITH THE CONTROL. THE LEADS FROM THIS POTENTIOMETER SHOULD BE KEPT AS SHORT AS POSSIBLE AND RUN IN A SEPARATE CONDUIT FROM THE AC INPUT AND MOTOR LEADS.
3. IF MOTOR DOES NOT HAVE F1 AND F4 LEADS, CONNECT F2 OF THE MOTOR TO 1TB-A(F-) ON THE CONTROL. CHECK THAT MOTOR VOLTAGES ARE COMPATIBLE WITH OCC OUTPUTS.
 - (a) TERMINALS 1 TO 2 ON 1TB 0-180VDC
 - (b) TERMINALS 3 TO 4 ON 1TB - 300VDC
 (ON PERMANENT MAGNET MOTORS NO CONNECTIONS SHOULD BE MADE TO TERMINALS 3 AND 4.)
4. THE BARRED CONTACTS IN SERIES WITH THE A1 AND A2 LEADS OF THE MOTOR ARE SHOWN IF A DC LOOP CONTACTOR IS TO BE USED. WITH A DC LOOP CONTACTOR REMOVE THE FUSED JUMPER BETWEEN TERMINALS 10 AND 11 ON 1TB. IN ITS PLACE USE AN AUXILIARY N.O. CONTACT ON THE DC LOOP CONTACTOR. THE OCC CONTROL IS RESET WHEN THE CONTACT IS OPEN AND ABLE TO RUN WHEN THIS CONTACT IS CLOSED. FAILURE TO REMOVE THE FUSED JUMPER AND TO USE THE N.O. AUXILIARY CONTACT WILL CAUSE FUSE BLOWING AND POSSIBLE CONTROL DAMAGE.
5. FOR APPLICATIONS REQUIRING EXTERNAL TORQUE PROGRAMMING AND/OR TORQ FREQUENCY REFER TO MANUAL FLOOR-TRIP FOR NECESSARY CONNECTIONS AND BOARD MODIFICATIONS.
- 6.

RMS INPUT CURRENT
230 VAC INPUT

HP SIZE	RMS INPUT CURRENT
1/4	3.0
1/3	4.0
1/2	5.0
3/4	7.0
1	11
1 1/2	15
2	20
3	30

SIZE 1L, 1L2, A1 AND A2 WIRING TO CARRY THE ABOVE CURRENT. SIZE MOTOR FIELD WIRING TO CARRY 2 AMPS.

FIGURE 5.

DRAWING NO.	C	POLYSPEDE ELECTRONICS CORP.
DRAFTSMAN	DATE	8770 TWIN HILLS AVE. DALLAS, TEXAS
APP'D.	DATE	OCC2 EXTERNAL WIRING CONNECTIONS 230VAC 1/4 THRU 3HP
SCALE	SHEET NO. 1	TOTAL NO. SHEETS 1
		A1404-000-EW, b

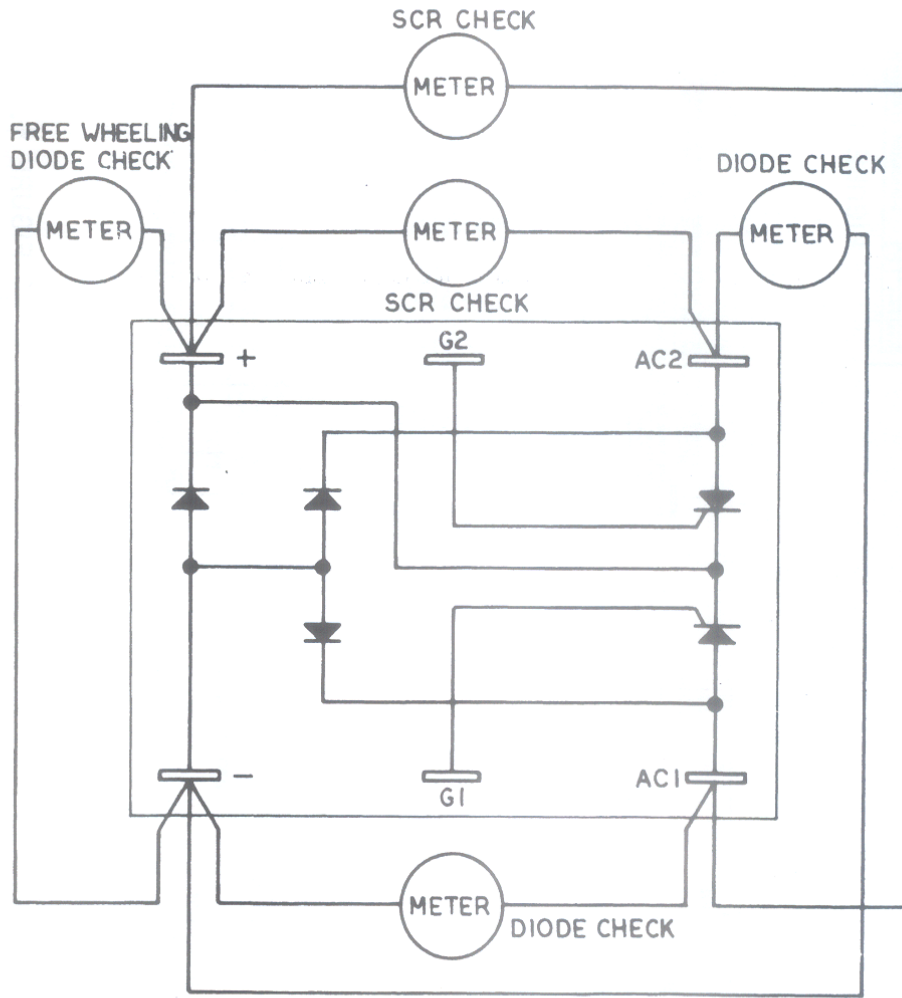

INTERNAL VIEW OF POWER CUBE WITH
METER PLACEMENT FOR SPECIFIC
SEMICONDUCTOR CHECKS.

POWER CUBE SEMICONDUCTOR TEST POINTS.
FIGURE 6

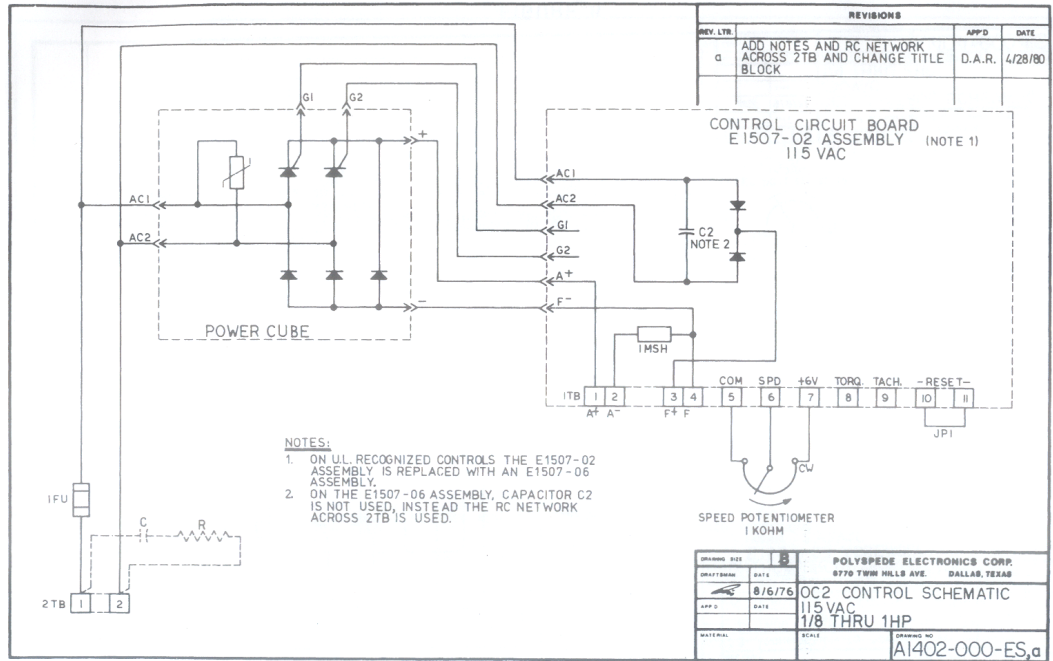

FIGURE 7

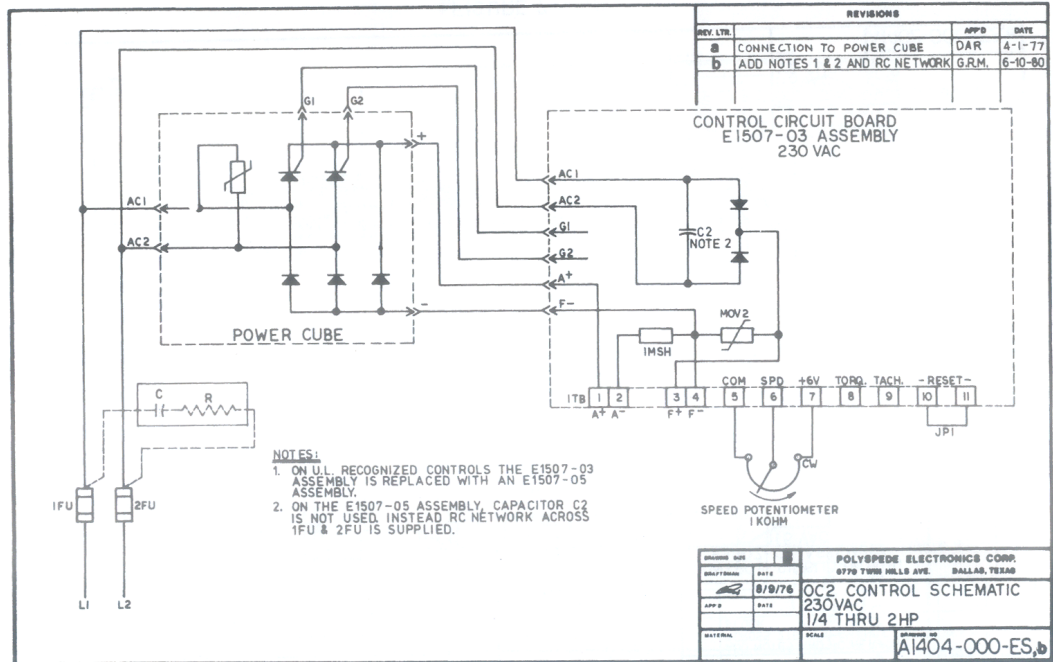

FIGURE 8

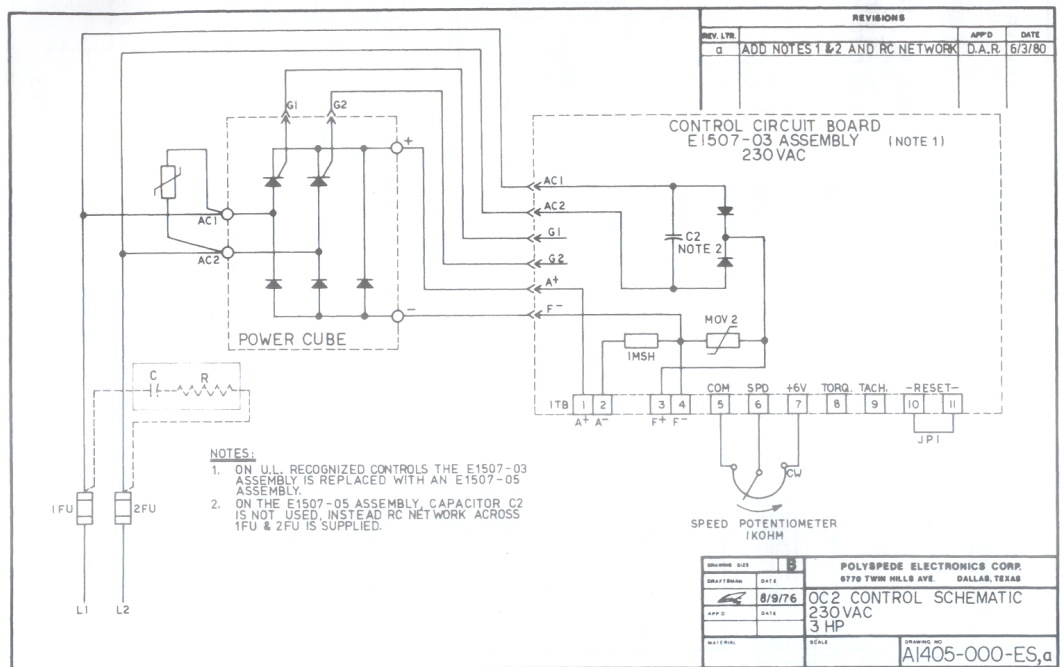

FIGURE 9

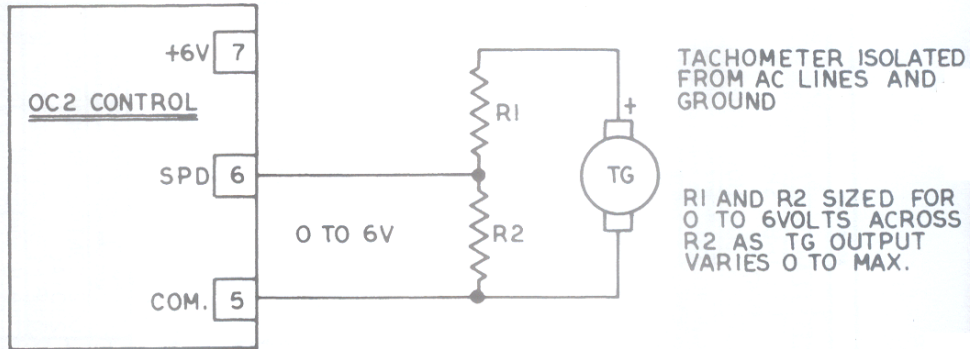

FIG. 10.1 EXTERNAL VOLTAGE SOURCE
(TYPICAL TACHOMETER FOLLOWER CIRCUIT)

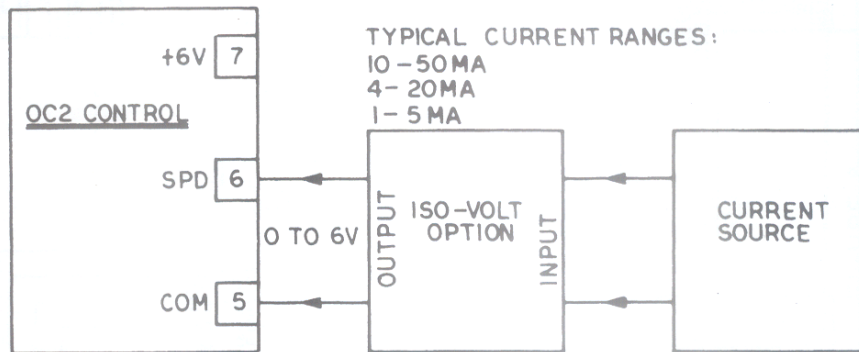

FIG. 10.2 EXTERNAL CURRENT SOURCE
(PROCESS INSTRUMENT)

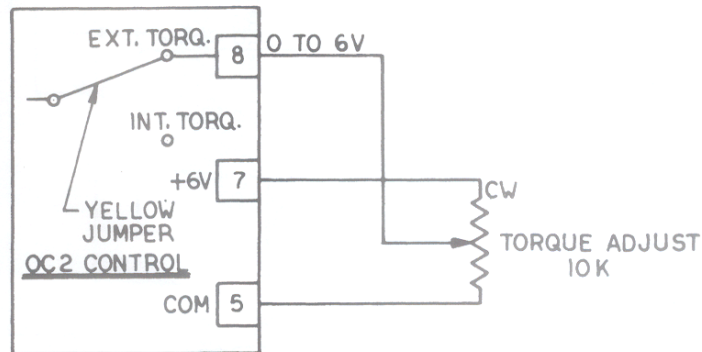

FIG. 10.3 EXTERNAL TORQUE LIMIT
(USING AN EXTERNAL POTENTIOMETER)

EXTERNAL SIGNAL PROGRAMMING
FIGURE 10

